

Encoder solutions for the steel and metal industry

Encoders for steel and metal industry

Encoders for steel and metal industry

 **Baumer**
Passion for Sensors



บริษัท โพรพลัส คอร์ปอเรชั่น จำกัด

22/354 หมู่ 4 ตำบลบึง อำเภอกศรีราชา จังหวัดชลบุรี 20230

Mobile : 099-6103519 | 099-7358459

Tel : 033-130209

Email : Sales@propluscorp.co.th

Web : www.Propluscorp.co.th



@propluscorp

ยินดีให้คำปรึกษา หรือสอบถามสินค้าบริการได้ตลอดเวลา

 /propluscorp

 /abbjokabthailanddistributor

 /propluscorp





Failure free. Safe. Efficient. At all times!

The degree of automation is crucial for a steel plant's competitive edge and its failure-free operation.

Continuously enhancing manufacturing methods, improved material and inspection technologies and very narrow tolerances throughout the entire production process present ever-growing requirements to sensor and interface technology.

Hence, present-day data availability can be used to improve production efficiency and quality control.

Being a long-year partner in the steel industry, we provide a broad product portfolio to meet all the varied customer and application-specific demands at an international level.

Opposing requirements range from sophisticated sensor technology for demanding specialized steelmaking on to price-oriented solutions for standard steel plants. In any case, we provide the robust and dependable sensor technology to ensure failure-free operation.

Process competence and system solutions

In more than 60 years of steel industry experience, Baumer has been significantly contributing towards reduced down time, increased system availability and improved product quality.

Failure-free production

This reflects in our particularly robust encoders, reliable centrifugal switches and optimally matching installation and mounting accessories.

Baumer – your expert partner on-site

Your Baumer contacts are experts knowing your industry and its special requirements. Your benefit: Efficient and competent consult – across the globe. Contact us.



Content.

Unparalleled HeavyDuty competence	4
The key to our HeavyDuty success	6
Incremental and absolute industry encoders	8
Application competence and quality for your plant	10
Steel making	12
Continuous casting	14
Main drives in rolling mills	18
Rolling mills and finishing lines	22
Overhead cranes	26
Accessories	30
Sensor solutions for the steel and metal industry	32
Encoders for the steel and metal industry	34



Learn more!
Data sheets and further information
on our products at:
www.baumer.com/metal

Unparalleled HeavyDuty compe- tence – proven quality since 1955.

- **The decisive contribution to downtime reduction**
Thanks to our industry expertise gained over many years and the close cooperation with machine and plant manufacturers, Baumer products excel with robust mechanical designs and extreme durability and lifetime.
- **Enhanced system availability and product quality**
Baumer HeavyDuty products set benchmarks and meet the demanding requirements of the steel and metal industry.
- **Your one-stop supplier for any steel plant encoder**
Baumer is an innovative single-source partner in the steel industry with extensive problem-solving expertise. Baumer offers a broad portfolio of HeavyDuty products along with an unmatched range of standard industry encoders.
- **Short delivery times and prompt service by global presence**



The Original from Berlin – globally unique

Baumer Hübner, former Hübner Berlin, is the Baumer Competence Center for HeavyDuty encoders in drive technology. For nearly 60 years we have been world leader in this field, setting technology benchmarks for reliable encoders, tachogenerators and speed switches. They play to their strengths where conventional encoders fail. Their design is tailored to the application to ensure dependable operation you can rely on – at all times.



HUBNER
BERLIN
A Baumer Brand



Baumer



n when it's rough – precise in performance.

In 1955, Hübner Berlin developed the first encoder for the steel industry, which was tacho generator TDP 5,5 designed for rolling mills.

Today, the worldwide unrivaled HeavyDuty portfolio comprises absolute, incremental and bearingless encoders meeting the demanding requirements in steel plants all over the world.

The HeavyDuty Competence center in Berlin implements cutting-edge production technologies.



The key to our HeavyDuty success – outstanding engineering expertise.

Bearings on both shaft ends for maximum service life

For more than 100 years, one bearing at each shaft end has been a proven construction principle in electrical machinery. Applied to mechanical encoder design, this means bearings provided at the opposing sides of the housing.

The interplay of two-sided bearings, robust Baumer mechanics and large ball bearings at optimum distance to compensate situation-induced shaft loads presents a performance class of its own.

Baumer HeavyDuty encoders are experienced as being unparalleled durable and long-life – this combination is basis and guarantee why. In practice, this means: Ultimate reserve capacity and improved system availability by reduced maintenance effort. Even in harshest conditions. A true Baumer HeavyDuty encoder.

Tough where it's rough, precise in performance.



Long-term seal against ingress of dust and liquids

- Specialized housing sealing concept
- Long-term stable shaft seal by Simmering, HOG 10, HMG 10 and PMG series with additional labyrinth seal
- High temperature range up to 100 °C
- High protection class

Easy installation

- Shaft with wrench flat for particularly easy attachment



Easy installation and integration

- 180° turnable terminal box enables connection from both sides providing for an optimum cable outlet
- Separate terminal box allows for pre-prepared routing regardless of later encoder installation position
- Quick cable connection by integrated terminal connector
- Terminal box with D-Sub can be used as standard plug (HOG 10 series)



Robust design for absolute reliability throughout the entire service life

- Solid housing made of aluminium or stainless steel
- Extremely strong walls, more than 10 mm thick
- Electronics protected during installation
- Additional protective coating



High-performance output drivers for long-distance transmission

- HTL-P with power line driver for signal transmission up to 350 m
- TTL technology for transmission up to 550 m
- Fiber-optic cable (optional accessory), up to 1500 m

Bearings on both shaft ends for maximum service life

- Large ball-bearings at optimum distance
- Designed to endure extremely high shaft loads

Protection against capacitive shaft currents

- Housing inside with polyamide isolation for shaft insulation and encoder voltage protection up to 2.8 kV
- Alternative protection by optional hybrid bearings with ceramic ball bearings
- Optional motor earthing unit for shaft current discharge

Easy integration thanks to matching accessories

- Torque support plate with versatile mounting options

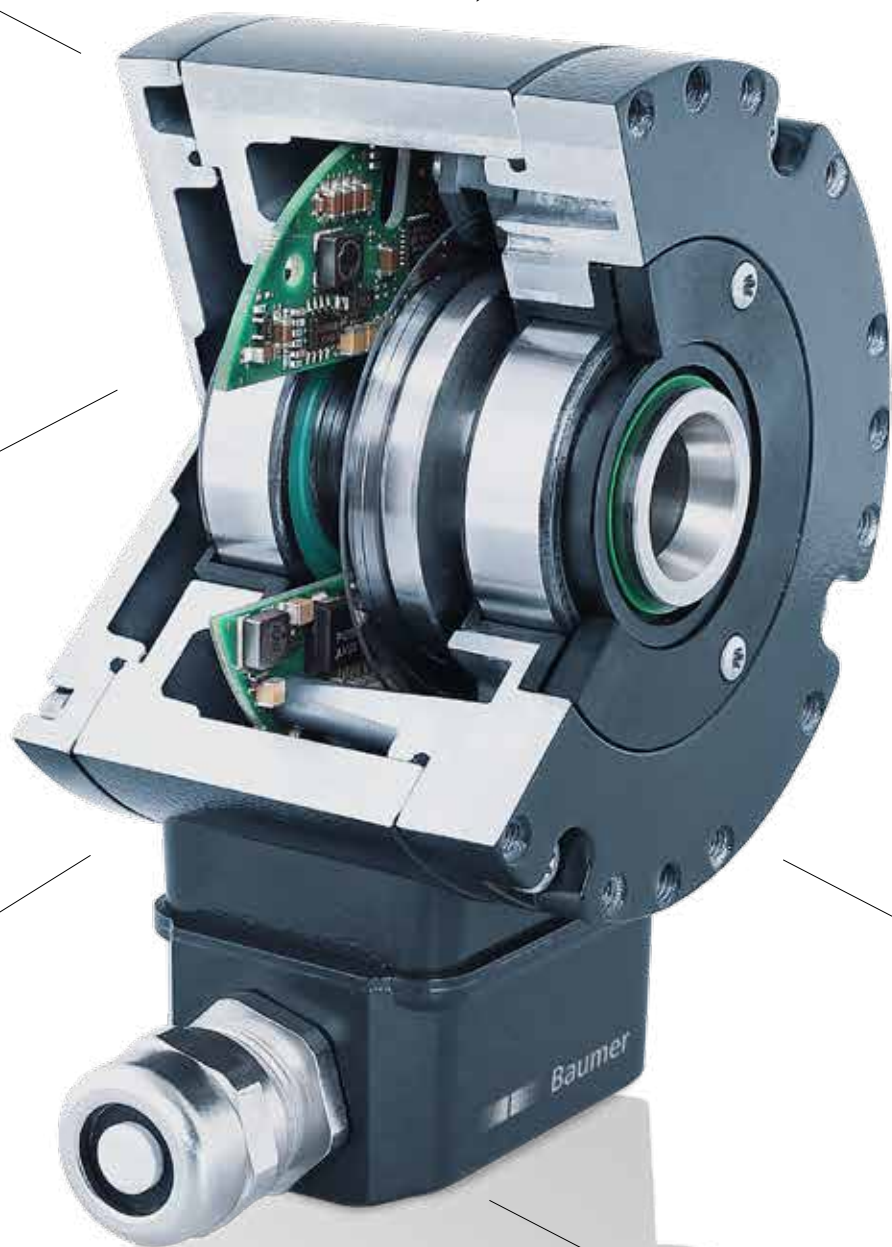
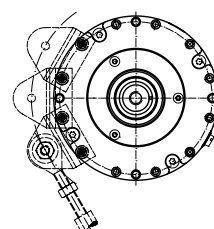

Incremental and absolute industry encoders.

Flexible. Robust. Precise.



Incremental encoders

Precise optical sensing
(e.g. series *OptoPulse*® EIL580)

- Outstanding precision and signal quality
- Code disc with high-precision increments for reliable measured results without interpolation errors
- Enhanced reliability by limited number of components
- Robust *ShaftLock* bearing concept



Absolute encoders

Robust magnetic sensing
(e.g. series *MAGRES* BMMV58)

- Extremely robust sensing technology for high resistance against shock and vibration
- Protection ratings up to IP 67
- Variant *MAGRES* hermetic in stainless steel and IP 69K protection
- Resolution up to 14 bits per turn
- Compact designs 30, 42, 58 mm
- Touchless Multiturn, wear free without gearing
- Robust *ShaftLock* bearing concept

ShaftLock – for outstanding durability

The metal support between the two ball bearings protects the bearings against axial shocks and load. This is the patented *ShaftLock* concept developed by Baumer. High-end materials and high-precision mechanics ensure optimum runout properties throughout the entire lifetime.





Absolute encoders

Precise optical sensing
(e.g. series GXMMW, GBMMW)

- Immediate position feedback
- Additional incremental signals
- Accuracy up to $\pm 0,01^\circ$
- High-resolution up to 18 bits per turn
- 58 mm housing and large hollow shaft design up to 51 mm
- Touchless Multiturn, wear free without gearing
- Robust *ShaftLock* bearing concept

Every common interface:



Application expertise and quality for your plant.

For decades, Baumer has been developing innovative products and customer-specific solutions in close cooperation with machine and system manufacturers. The broad portfolio of position and motion sensors for the HeavyDuty industry excels with intelligent designs, resilient technologies and high-end materials. This way, Baumer products meet even the most demanding requirements on reliability and durability and hence support our customers in their striving for maximum system availability.

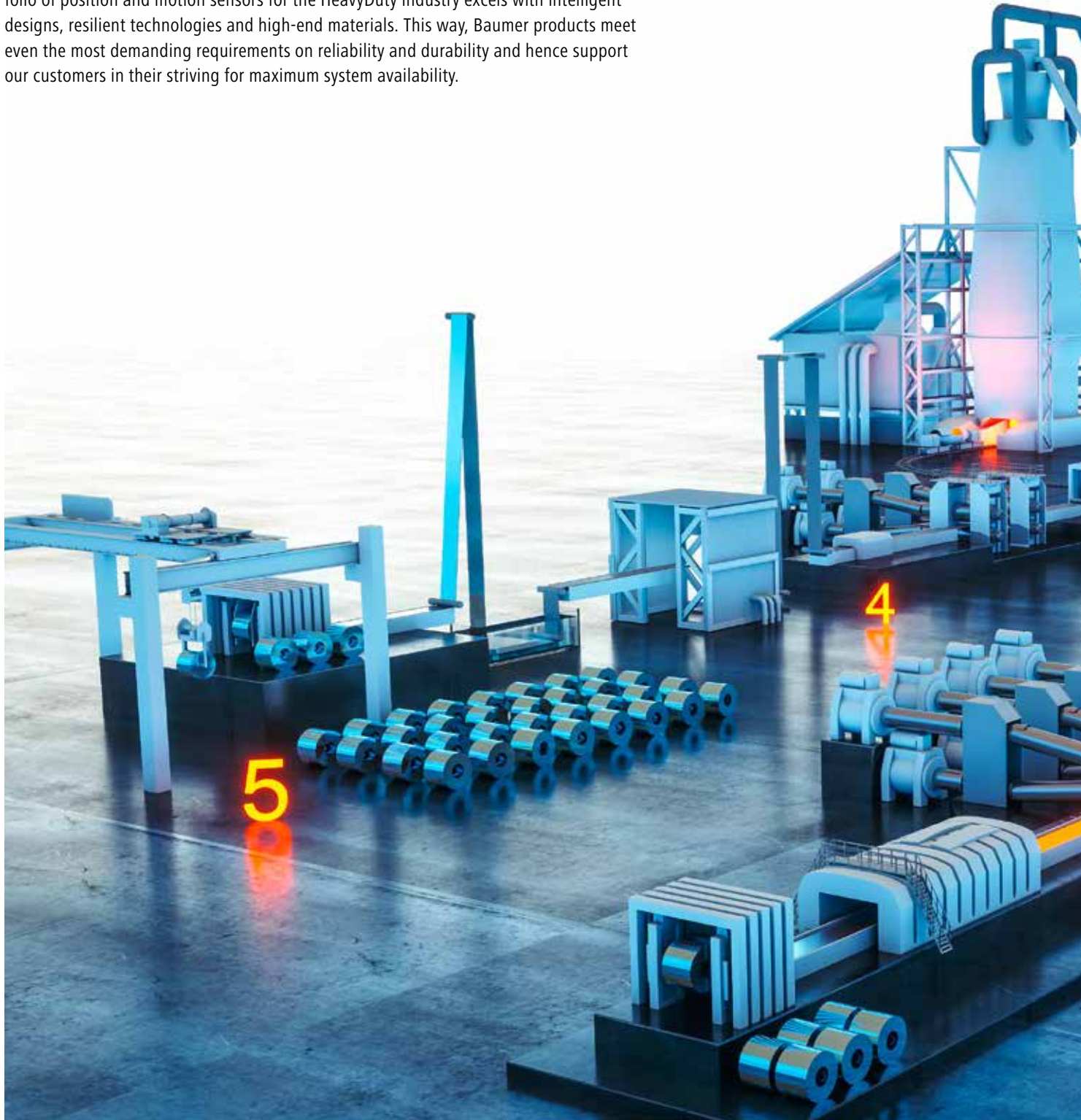

Steel making

1

Continuous casting

2

Main drives in



rolling mills

3

Rolling mills and finishing lines

4

Overhead cranes

5

Steel making.

In steel and metal applications, encoders are exposed to shock, vibration and adverse ambient conditions such as dust and extreme temperatures.

Extra installation flexibility provide encoders with mounting base. Particularly in retrofitting or where using extended functionalities at existing measuring spots, these encoders allow for quick integration without much effort. Installation separated from the machine disengages the encoder from any transferred shock and vibration impacts.

1 Position feedback at converter tilting drives

HeavyDuty encoders by Baumer reliably supply the converter position information even at strong shock and vibration and in harsh environments. This way, they ensure smooth operation at the correct position.

2 Rotation speed feedback at converter tilting drives

Encoders are a key automation element at tilting drives and significantly contribute towards safety. Their precise signals support safe operation control and prevent the converter from uncontrolled tilting or mispositioning.



MicroGen multiturn sensing for absolute HeavyDuty encoders

- Energy Harvesting technology in PMG 10/HMG 10 realised by patented multiturn-technology *MicroGen* of latest generation
- In tough HeavyDuty use for over 10 years
- Wear free, no gearings
- Environment-friendly and maintenance free without battery
- Wide temperature range from -40 to 100 °C

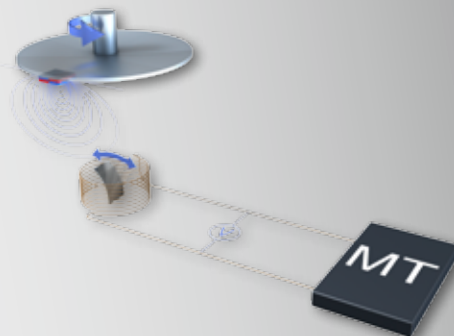



Electric arc furnace, blast furnace and converter.

HeavyDuty



1 2

Series HeavyDuty PMG 10
Position and rotation speed feedback at
converter tilting drives

Absolute multiturn encoder of unparalleled durability through HeavyDuty design with two-sided bearings and extremely precise magnetic sensing

- Multiturn encoder 20/20 bits in solid shaft design and EURO flange B10
- Robust, extremely precise magnetic single-turn sensing
- Energy self-sufficient *MicroGen* multiturn generator of latest generation
- Two additional incremental signals with zero pulse
- Shaft loads up to 650 N radial and 450 N axial
- Hollow shaft designs in series HMG 10

HeavyDuty



2

Series HeavyDuty POG 10
Rotation speed feedback at converter
tilting drives

Absolute, incremental encoder with high service-life in solid shaft design

- Up to 5000 ppr
- As twin encoder for enhanced system availability
- Optional with redundant sensing
- Optional with foot mounting
- Easy installation by large terminal box, 180° turnable
- Hollow shaft designs in series HOG 10

Ladle turret and cutting to length.

HeavyDuty



1

Series HeavyDuty PMG 10
Position feedback at ladle turret

Absolute multiturn encoder of unparalleled durability through HeavyDuty design with two-sided bearings and extremely precise magnetic sensing

- Multiturn encoder 20/20 bits in solid shaft design and EURO flange B10
- Robust, extremely precise magnetic single-turn sensing
- Energy self-sufficient *MicroGen* multiturn generator of latest generation
- Two additional incremental signals with zero pulse
- Simultaneous shaft loads up to 650 N
- Hollow shaft designs in series HMG 10



2

Series *MAGRES* BMMV 58
Position feedback while cutting to length

Absolute encoder with robust magnetic sensing in solid shaft design, extremely resistant against shock and vibrations

- Multiturn encoder, 12/18 bits with robust magnetic sensing
- Shock and vibration proof up to 500 g/30 g
- SSI, every common fieldbus and Ethernet interface
- Robust *ShaftLock* bearing concept
- Solid shaft 10 mm
- Hollow shaft designs in series BMMH 58



2

Series GXMMW
Position feedback while cutting to length

Absolute precise optical encoder with additional incremental signals in solid shaft design

- Absolute multiturn encoder, 13/16 bits, high-resolution variants up to 18/13 bits
- SSI, BiSS C and all common fieldbus and Ethernet interfaces
- Rapid position feedback
- Robust *ShaftLock* bearing concept
- Solid shaft designs up to 10 mm
- Hollow shaft designs up to 14 mm in series GBMMS



Continuous casting.

Shock, vibration, heat and dust are ever present at continuous casting platforms. Extremely high humidity during the cooling process is another demanding challenge. From our long-standing collaboration with drive and plant manufacturers in steelmaking evolve encoders which have proved in this industry-specific adverse conditions by their unrivaled robust design and multi-layer sealing concepts.

1 Position feedback at ladle turret

For this extremely demanding application Baumer provides the ultra-durable absolute HeavyDuty encoders. The magnetic sensing of the PMG 10 provides signals with the precision of an optical scanning unit, especially at high temperature and adverse ambient conditions. By our non-contact multiturn technology *MicroGen* they provide high operational safety even under most adverse conditions.

2 Cutting to length

Absolute encoders reliably acquire throughput speed and length of the slab and supply the accurate measured value for the cut to length. Baumer encoders support all common interfaces and ease integration into control level.

Continuous casting.

The Baumer world-wide unparalleled encoder portfolio will master any task in speed and position feedback at auxiliary drives in steel plants.

1 Rotation speed feedback at auxiliary drives

Baumer HeavyDuty encoders with resolutions up to 5000 ppr ensure precise speed feedback even under permanent vibration and shock impact. Furthermore, the encoders endure ambient temperatures up to 100 °C. The high-performance output drivers meet the requirements of long-distance transmission.



Excellent signal quality

The high-performance and robust output drivers integrated in all incremental HeavyDuty encoders ensure excellent signal quality for reliable evaluation even in transmissions with up to 550 m (TTL) respectively 350 m (HTL-P) cable length.

The diagram is an example of the HOG 86 HTL signal amplitude after 300 m at 100 °C and with 100 kHz output frequency. The competitive product supplies only half the signal amplitude at inferior signal quality which may lead to evaluation problems.

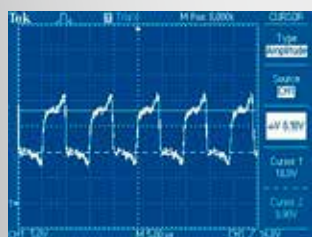

Competitive product

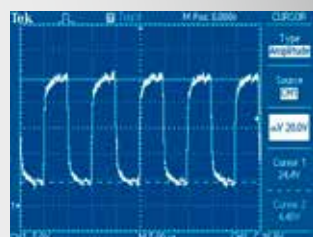

Baumer HOG 86



Auxiliary drives.

HeavyDuty



1
 Series HeavyDuty HOG 86
 Rotation speed feedback at auxiliary drives

The incremental HeavyDuty standard with high service life for demanding environments with blind hollow shaft

- Encoder with optical sensing
- Up to 5000 ppr
- Optional with redundant sensing
- High mechanical reserve capacity with mere 70 mm installation depth
- Blind hollow shaft up to 16 mm

HeavyDuty



1
 Series HeavyDuty POG 86
 Rotation speed feedback at auxiliary drives

Industry standard HeavyDuty incremental encoder in solid shaft design, proven in steel plants and extremely long-life

- Encoder with optical sensing
- Up to 5000 ppr
- Optional redundant sensing
- Available as twin encoder for particularly high availability
- Easy installation by separately configurable terminal box turnable through 180°
- 11 mm solid shaft design



1
 Series HS35
 Rotation speed feedback at auxiliary drives

Incremental encoder for large shaft diameters in mm or inch, with MIL connector and through hollow shaft

- Up to 80 000 ppr
- Resolution programmable
- Rectangular or SinCos signals
- IP 67 protection
- Robust *ShaftLock* bearing concept
- Through hollow shaft up to 25,4 mm (1")

Main drives in rolling mills.

In hot and cold rolling mills, consistently high product quality calls for precise speed signals at the main drive.

1 Rotation speed feedback at main drives

The Baumer HeavyDuty incremental encoders merge high resolution with high precision which allows for optimal synchronization of the input and output speed of several mill stands in a row. In such environments, the high mechanical reserve capacity will ensure safe and failure-free operation and eliminate misproduction and downtime. Deployed in conjunction with programmable speed switches, all encoders with integral bearings will reliably protect engine and installations against overspeed.

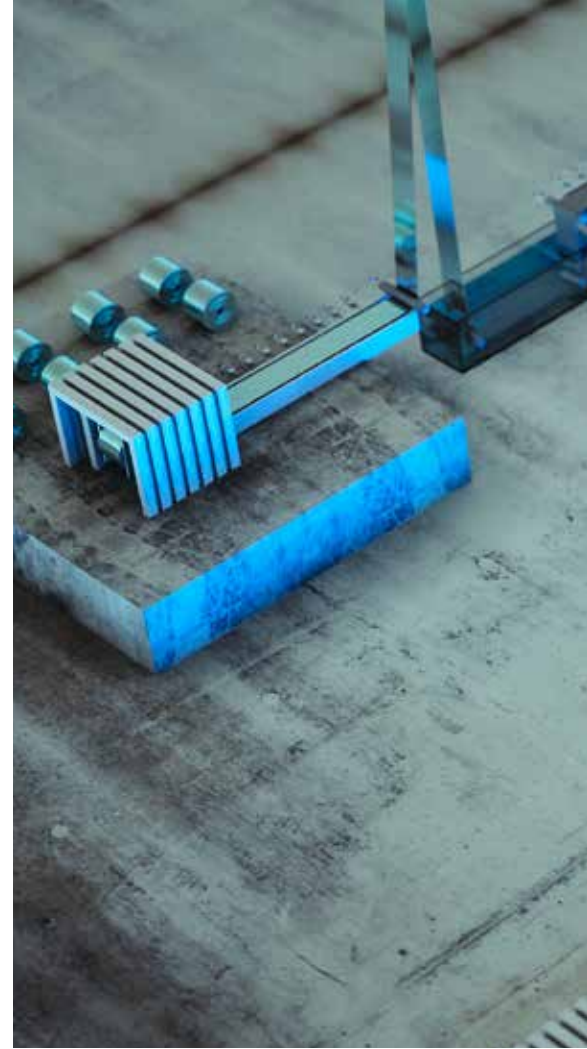

HDmag – bearingless encoders by Baumer

Magnetic sensing is insensitive to dust and condensation which is a prerequisite for dependable operation in the heavy duty industry. In addition, non-contact technology allows for large tolerances on axial and radial backlash. This will ensure excellent signal quality even at strong shock and vibration.

State-of-the-art processing makes the most of the supplied high-quality precision signals to generate high resolutions for versatile use. The *HDmag* family with fully encapsulated electronics is compliant to IP 67 rating and hence provides reliable protection against the ingress of dust, dirt and liquids throughout the entire service life.

The troubleshooter for narrow installation space.



1

Series *HDmag* MHGP 400
Rotation speed feedback at main drives

Bearingless encoder for extremely large shafts, for direct drive shaft attachment or where space is limited

- Incremental encoder with magnetic sensing
- Free selection of any resolution up to 524 288 ppr
- Wear free, non-contact sensing
- Insensitive to dust, dirt, liquids
- Encapsulated electronics
- Through hollow shaft up to 340 mm

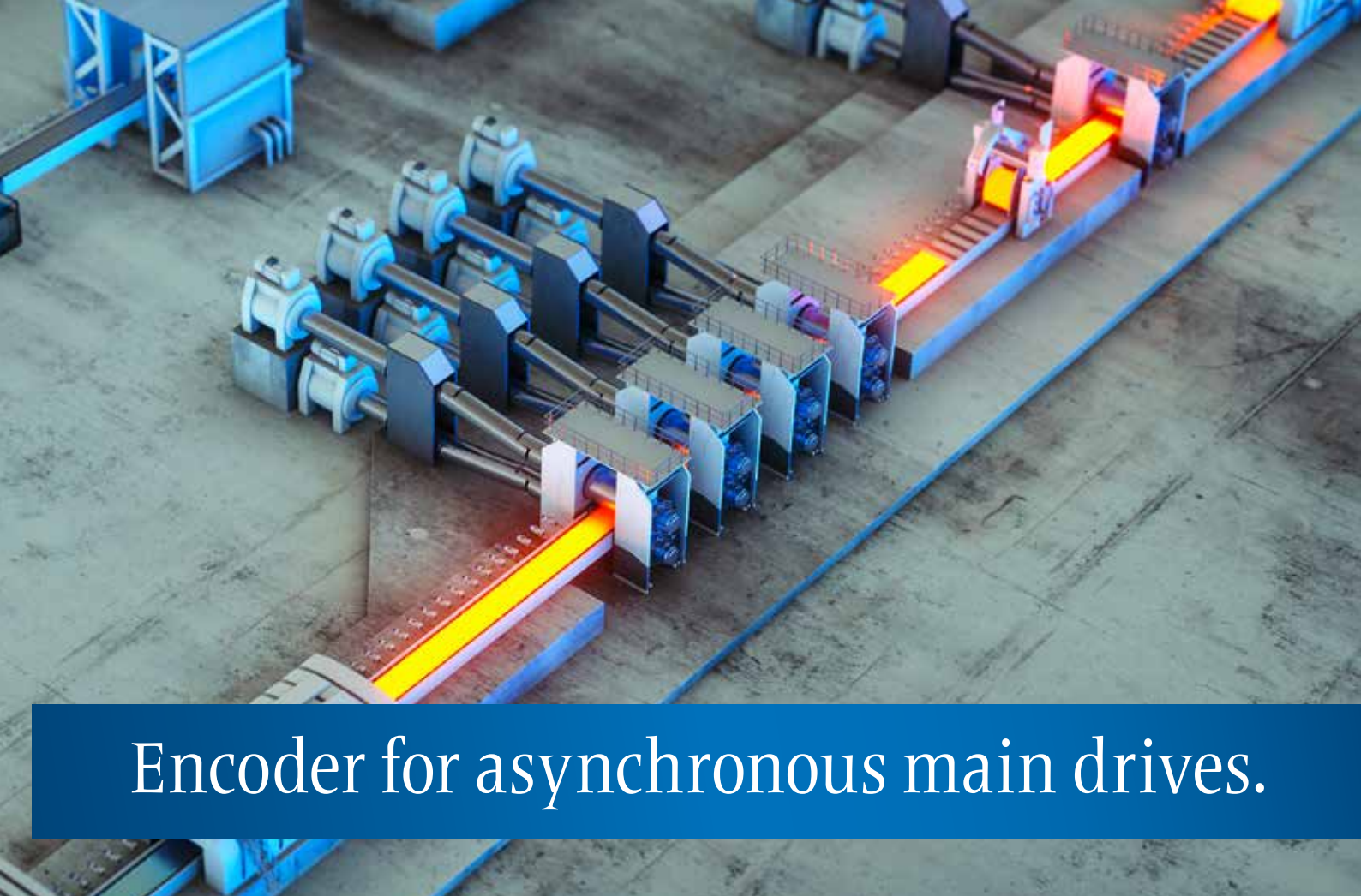

Encoder for asynchronous main drives.

HeavyDuty



1
Series HeavyDuty HOG 165
Rotation speed feedback at main drives

Encoder with blind hollow shaft for large diameters and high-power main drives

- Incremental, optical encoder
- Up to 8192 ppr for speed feedback at low rotation
- High resistance against shock and vibration
- Intermediate flange for easy and safe installation at main drives
- Blind hollow shafts up to 38 mm
- Optional: programmable speed switch

HeavyDuty



1
Series HeavyDuty HOG 10
Rotation speed feedback at main drives

For decades the HeavyDuty benchmark with unrivaled durability and blind hollow shaft design

- Incremental optical encoder
- Up to 5000 ppr for speed feedback at low rotation
- Sophisticated sealing concept for perfected dust protection
- Industry-proven thousands of times, best-selling encoder in its class
- Speed switch either programmable or mechanic
- Blind hollow shafts up to 20 mm

HeavyDuty



1
Series HeavyDuty HOG 10 G
Rotation speed feedback at main drives

Maximum availability and unrivaled durability by two redundant twin encoders installed at the same shaft

- Incremental, optical encoder for redundant speed feedback
- Up to 5000 ppr for speed feedback at low rotation
- Sophisticated sealing system for perfect dust protection
- Each twin to come with its individual resolution
- Blind hollow shafts up to 20 mm



Encoders for synchronous main drives.



1

Series *HDmag* MHAP 200
Position and speed feedback at main drives

Bearingless encoder for extremely large shafts, direct drive shaft attachment or where space is limited

- Absolute bearingless encoder with magnetic sensing
- 17 bit singleturn resolution
- Shaft diameters up to 340 mm
- Wear free sensing
- By principle immune against shaft currents
- High-resolution output signals with low jitter

HeavyDuty



1

Series HeavyDuty HMG 10
Position and speed feedback at main drives

Absolute multiturn encoder of unparalleled durability by HeavyDuty design and magnetic sensing for precise rotor feedback

- Multiturn encoder 20/20 bits
- Extremely precise magnetic singleturn sensing
- Energy self-sufficient *MicroGen* multiturn generator of latest generation
- Two additional incremental signals with zero pulse
- Simultaneous shaft loads up to 650 N radial and 450 N axial
- Programmable digital speed switch



Main drives in rolling mills.

1 Position and speed feedback at main drives

For smooth ramp-up at highest possible torque, the synchronous motor control unit requires precise commutation. Baumer absolute HeavyDuty encoders provide precise rotor position feedback even under adverse ambient conditions. Additional incremental signals enable parallel speed feedback for optimally synchronized in-line speed and consistently high product quality.

Motor earthing unit

The durable Baumer motor earthing unit dependably discharge parasitic currents and this way protect the bearings against shaft currents for maximum service life, while reducing repair cost and downtime in parallel.

The price is only a fraction of the costs for a bearing exchange.

Series ME 12 comprises motor earthing units for shaft diameters from 20 to 42 mm.



Series ME 12

Rolling mills and finishing lines.

1 Rotation speed feedback at rolling mills

Speed synchronization is a crucial quality and quantity criterion throughout the entire rolling process. Baumer offers the broadest encoder portfolio for all kinds of transport and auxiliary drives to meet any motor or speed requirements and master transport tasks in all their facets.



HOG 86 – the HeavyDuty encoder with reserve capacity

- Extremely robust
- Safe and precise
- Easy to install
- Failure-free in any environment
- Protected against shaft currents
- Dependable operation even at extreme temperatures
- Defying high shaft loads





Auxiliary and roller table drives.

HeavyDuty



1

Series HeavyDuty HOG 86
Rotation speed feedback at roller table drives

The incremental HeavyDuty standard encoder in blind hollow shaft design. Outstanding durability for demanding environments

- Encoder with optical sensing
- Up to 5000 ppr
- Optional redundant sensing
- High mechanical reserve capacity, shallow installation depth of 70 mm
- Blind hollow shafts up to 16 mm



1

Series HS35
Rotation speed feedback at roller table drives

The incremental encoder for large shafts in mm or inch, with MIL connection technology and in through hollow shaft design

- Encoder with optical sensing
- Up to 5000 ppr resp. highly-resolving and programmable up to 65 536 ppr
- Programmable resolution
- Rectangular or SinCos signals
- IP 67 protection
- Robust *ShaftLock* bearing concept
- Through hollow shaft up to 25.4 mm (1")



1

Series *OptoPulse*® EIL580/EIL580P
Rotation speed feedback at roller table drives

The robust and cost-efficient solution for auxiliary or roller table drives

- Incremental optical encoder
- Up to 5000 ppr resp. highly-resolving and programmable up to 65 536 ppr
- Robust *ShaftLock* bearing concept endures shaft loads up to 80 N radial, 40 N axial
- Also available with EURO flange B10
- Optional insulation against shaft currents
- Blind hollow shaft or through hollow shafts up to 15 mm

Coil boxes and loopers.

HeavyDuty



2

Series HeavyDuty PMG 10
Position feedback at loopers

Absolute multiturn encoder of unparalleled durability through HeavyDuty design with two-sided bearings and extremely precise magnetic sensing

- Multiturn encoder 20/20 bits in solid shaft design and EURO flange B10
- Robust, extremely precise magnetic single-turn sensing
- Energy self-sufficient *MicroGen* multiturn generator of latest generation
- Two additional incremental signals with zero pulse
- Simultaneous shaft loads up to 650 N
- Hollow shaft designs in series HMG 10

HeavyDuty



2

Series HeavyDuty HOG 10
Relative position feedback at loopers

For decades benchmarking in HeavyDuty, unrivaled durability in blind hollow shaft design

- Incremental optical encoder
- Up to 5000 ppr for low speed rotation
- Sophisticated sealing concept for perfected dust protection
- Industry-proven thousands of times, best-selling encoder in its class
- Speed switch either programmable or mechanic
- Blind hollow shafts up to 20 mm

HeavyDuty



1

Series HeavyDuty HOG 86
Speed feedback at coil boxes

Incremental HeavyDuty standard with high life span for demanding environments with blind hollow shaft design

- Encoder with optical sensing
- Up to 5000 ppr for low speed rotation
- Redundant sensing as an option
- High mechanical reserve capacity and mere 70 mm installation depth
- Blind hollow shafts up to 16 mm

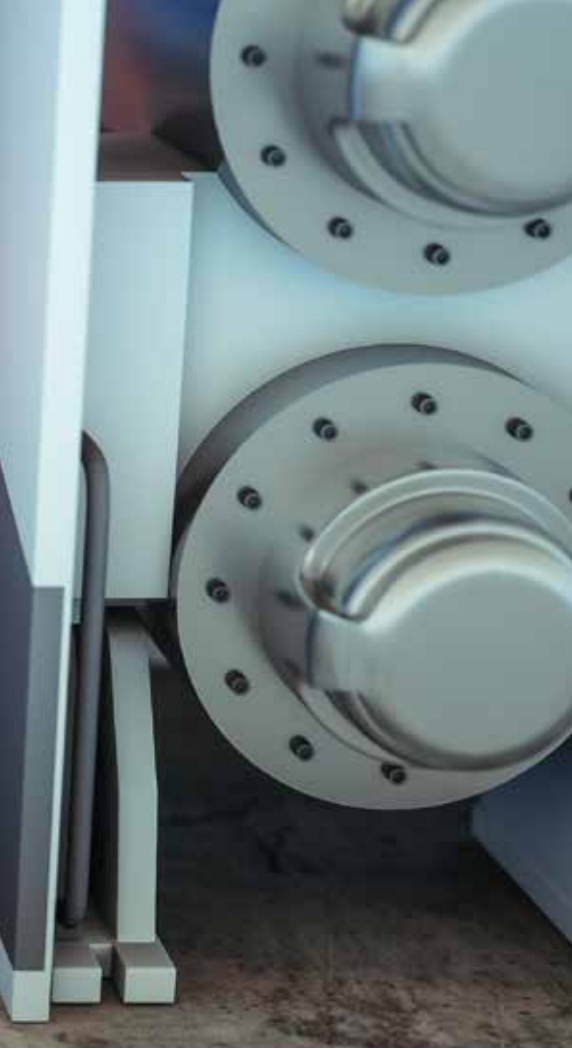

Rolling mills and finishing lines.

In rolling mills there is a multitude of positioning tasks, for example alignment operations in side compression or shears positioning. Baumer has the matching encoder for every task.

1 Speed and position feedback at coil boxes

At coil boxes, precise speed feedback is crucial for even wind and unwind of long metal sheets, sometimes without using spindles. Reliable speed feedback allows for synchronized and harmonized individual roll speeds. Furthermore, constant product geometry requires position control at the bending rolls.

2 Position feedback at loopers

In the milling process, loopers control the amount of strain at the sheet metal between the rollers. They prevent any excess material building up in front of the roller and this way significantly contribute towards process stability. The narrow measuring angle of less than 90° causes the ball bearings being exposed to one-sided load. PMG 10 bearings are particularly designed to endure such unbalanced load impact and furthermore provide specialized greasing that endures any temperature within the wide range. Extreme resistance against shock and vibrations provide long-life capabilities and durability in harsh environments.

Where only the relative position information is required, HOG 10 with its large hybrid bearings compensating very high shaft loads is the optimum incremental solution.



1

Series *MAGRES BMMV 58*
Position feedback at coil boxes

Robust magnetic absolute encoder in solid shaft design with high immunity against shock and vibration

- Multiturn encoder, 12/18 bits with robust magnetic sensing
- Shock and vibration proof up to 500 g/30 g
- SSI, every common fieldbus and Ethernet interface
- Robust *ShaftLock* bearing construction
- Solid shaft 10 mm
- Hollow shaft designs in series BMMH 58

Overhead cranes.

1 Rotation speed feedback at hoists and hoist drives

Product combinations of encoder and speed switch are ideal for crane winch applications. Mechanical centrifugal switches and electronic, programmable speed switches detect any winch over-speed and prevent damage and personal injury.

Other product combinations offer increased availability or multiple signal use:

- Twin encoder hosting two independent encoder systems with user-configurable pulse numbers
- Redundant sensing by two galvanically isolated sensing systems within the same encoder
- Encoder and tachogenerator as two-in-one device supply both digital position signals and analog realtime signals.



Easy and dependable rotation speed monitoring

Mechanical speed switch (FSL)

- Field-proven and energy-autonomous
- Operates on the mechanical centrifugal principle
- User-specific switching speed set as default

Digital speed switch (DSL)

- User-programmable switching speed
- Integrated self-monitoring
- Up to three programmable switching speeds
- Integrated relay as an option



HeavyDuty



1

Series HeavyDuty HOG 10 + FSL/DSL
Rotation speed feedback at hoists and hoist drives

For decades the HeavyDuty benchmark with unrivaled durability, presented with blind hollow shaft design and with an integrated speed switch

- Incremental optical encoder
- Optionally with redundant sensing
- Product combination of incremental encoder and mechanical speed switch
- Transmission length up to 350 m (HTL)
- Insulates shaft up to 2.8 kV
- Sophisticated sealing concept for maximum dust protection
- Blind hollow shafts up to 20 mm



Hoists.

HeavyDuty



1
 Series HeavyDuty HOG 86 + FSL
 Rotation speed feedback at hoists and hoist drives

The HeavyDuty standard for maximum service life, integrated mechanical speed switch and in blind hollow shaft design

- Incremental, optical encoder
- Optionally with redundant sensing
- High resistance against shock and vibration
- Product combination of encoder and mechanical speed switch
- Signal transmission length up to 350 m (HTL)
- Insulated shaft up to 2.8 kV
- Blind hollow shafts up to 16 mm

HeavyDuty



1
 Series HeavyDuty HOGS 100 S
 Rotation speed feedback at hoists and hoist drives

Incremental SIL2 certified safety Heavy-Duty encoder with through hollow shaft

- Encoder with optical sensing
- Up to 5000 ppr for speed feedback at low rotation
- SIL2 approval
- Extremely low harmonic content in the output level thanks to patented LowHarmonics technology
- Optionally with mechanical speed switch
- Through hollow shafts up to 16 mm



1
 Series ITD 70 A 4
 Rotation speed feedback at hoist drives

Incremental industry encoder for hoist drives with hollow shaft design for particular large shaft diameters

- Encoder with optical sensing
- Up to 2500 ppr
- Shallow installation depth of mere 61 mm
- Through hollow shafts up to 65 mm

Crane bridge drives.



1

Series GBMMS
Position and rotation speed feedback at crane bridges

Absolute encoder for position feedback and additional incremental signals for speed feedback at crane bridges

- Multiturn encoder 18/13 bits with precise optical sensing
- Precision up to $\pm 0,01^\circ$
- Fast position detection
- Robust *ShaftLock* bearing concept
- Hollow shafts up to 14 mm
- 10 mm solid shaft designs in series GBMMW



1

Series MAGRES BMMV 58
Position feedback at crane bridges

Robust absolute magnetic encoder in solid shaft design, strong resistance against shock and vibration

- Multiturn encoder, 12/18 bits with robust magnetic sensing
- Shock and vibration proof up to 500 g/30 g
- SSI, every common fieldbus and Ethernet interface
- Robust *ShaftLock* bearing concept
- Solid shaft up to 11 mm
- Hollow shaft designs in series BMMH 58



1

Series OptoPulse® EIL580/EIL580P
Rotation speed feedback at crane bridges

The robust and cost-efficient solution for roller tables and auxiliary drives

- Incremental optical encoder
- Up to 5000 ppr resp. high-resolution and programmable up to 65 536 ppr
- Robust *ShaftLock* bearing concept for shaft loads up to 80 N radial, 40 N axial
- Also available with EURO flange B10
- Optionally with insulation against shaft currents
- Blind hollow shaft or through hollow shafts up to 15 mm



Overhead cranes.

1 Position and rotation speed feedback at crane bridges
Targeting exactly a defined position or lowering loads with pinpoint accuracy calls for precise encoders to supply the precise position information. Furthermore, they prevent the crane bridge drive from skewing and this way significantly contribute towards smooth and reliable crane operation.

Long-standing experience

Having evolved from long experience, Baumer encoders are designed for dusty environment in steel works and ensure a smooth process flow.



Accessories

Mounting accessories for hollow shaft encoders



Adaptor shaft, support plate and torque arm for HOG 165

- To adapt to large shaft of main drives
- Extended torque support
- Recommended for shafts with high axial or radial backlash



Torque arm support plates for HOG 10 / HOG 86

- Torque arm support plates for HeavyDuty encoders
- Extended torque arm support plates
- Recommended for shafts with high axial or radial backlash



Torque supports for small-sized industry encoders design

- Torque supports for 58 mm designs



Matching spring plates

- Wide selection for standard encoders (e. g. EIL580)
- Matching any installation requirement

Our complete range of accessories can be seen at www.baumer.com/accessories

Connection accessories



Broad range of cables

- Up to 500 m cable length
- Shielded, twisted in pairs
- Specialized cables for harsh environments
- Standard cables for the entire encoder portfolio

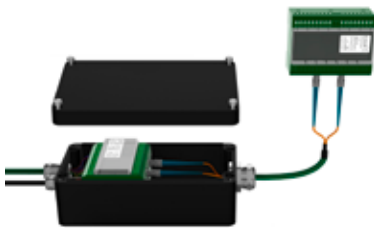

Fiber-optic outdoor box

- Incremental signal transmission up to 1500 m
- Outdoor box protects against adverse ambient conditions
- Dual fiber-optics for redundant signal transmission
- No transmission interruption in case one should fail
- No information loss in transmission where there is high EMC interference

Mounting accessories for solid shaft encoders



Tailored couplings for solid shaft encoders

- Metal bellows coupling
- Spring spacer coupling
- Double loop coupling

Smart accessories reduce radial runout by 60%

Manufacturing tolerances at the B side of large motor shafts entail radial runout which in turn will cause angular errors in the output signal and resonance oscillation in the speed signal. Particularly long torque arm support plates reduce radial runout by more than 60% since they increase the vertical gap (L1) between encoder center and torque support.

A calculation example drawn from practice:

Calculation of the mechanical angular misalignment as below:

$$\Delta\rho_{\text{mech}} = \pm 90^\circ/\pi \times K/L1$$

(K = radial runout, L1 = vertical gap)

With K = 0.06 mm and a gap of L1 = 63 mm, the above formula equals an angular misalignment of $\pm 0,027^\circ$.

$$\Delta\rho_{\text{mech}} = \pm 90^\circ/\pi \times 0.06 \text{ mm}/63 \text{ mm} = \pm 0.027^\circ$$

Extending L1 to 160 mm will reduce radial runout by nearly 60% down to $\pm 0,011^\circ$.

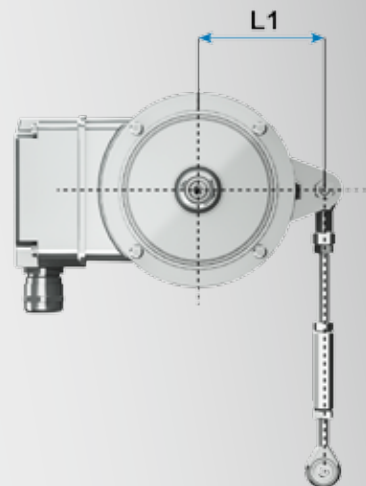



When the going gets tough.

Ultrasonic sensor solutions for demanding environments.

Reliable and precise level and object detection in tough conditions with dirt and dust by ultrasonic sensors

- High immunity against installation noise
- Wide measuring range 100 ... 6000 mm
- Reliable measured results, irrespective of object color or surface properties (even reflecting or high-gloss)
- Precise measurement even in dusty, dirty or humid environments
- Level detection at solid media, even under demanding conditions
- Robust sensors with IP 67 protection

Precise photoelectric measurements up to 4 m distance

- Sensing distance up to 4 m with 5 mm resolution
- Reliable measured results, independent of object color or properties, even demanding surfaces
- Highest performance in a compact design
- Excellent temperature stability
- Enables precise, repeatable measurements
- Fast measuring operations at short response time < 10 ms



Ultrasonic proximity sensor UZAM with up to 6 m sensing distance

Compact and robust ultrasonic sensor UR18 in 18 mm housing



Laser distance sensor OADM 250/260



Sensor solutions for the steel and metal industry – precision, quality and reliability.

Baumer sensors are deployed throughout the entire steel and metal industry. Whether level detection of bulk material by ultrasonic sensors, positioning or width measurement of sheet metal or position feedback of end stops using inductive sensors – the Baumer portfolio provides a wide selection.

Robust inductive sensor solutions – non-contact and dirt-insensitive detection of metal objects.

- High-temperature sensors up to 180 °C for hot-zone applications
- Robust all-metal sensors with IP 69K protection
- Outdoor sensors with longer product life by Baumer *proTect*⁺
- Sensors immune to weld and magnetic fields, teflon-coated active surface and chrome-plated housing, sensing distance up to 5 mm
- Shock and vibration-proof sensors

Broad portfolio of robust inductive sensors for non-contact measurement of changes in the position of metal objects.



Outdoor sensors
IFRR



DuroProx all-metal sensors
IFRD



Robust high-temperature sensors
IFRH



IFRW sensors – immune to weld
and magnetic fields

Encoders for the steel and metal industry

Selection guide

Incremental encoders

Size (ø)	HeavyDuty	Solid shaft (ø)	Hollow shaft (ø)	Through hollow shaft	Bearingless	EURO flange B10	Terminal box	Hybrid bearings	TTL / HTL	SinCos 1 Vss	Max. ppr	Redundant sensing	EMS	Programmable	Product family	Page
165 mm	■		20 ... 38 mm			■	■	■			8192				HOG 165	19
105 mm	■		12 ... 20 mm			■	■	■			5000	■	■		HOG 10	19, 24
105 mm	■		16 mm			■	■	■			2500				HOG 10 + DSL	26
105 mm	■		16 ... 20 mm			■	■	■			5000	■	■		HOG 10 + FSL	26
105 mm	■		16 ... 20 mm			■	■	■			5000	■	■		HOG 10 G	19
105 mm	■		16 mm			■	■		■		5000				HOGS 100 S	27
99 mm	■		12 ... 16 mm			■	□	■			5000		■		HOG 86	17, 23, 24
105 mm	■		16 mm			■	□	■			5000	■	■		HOG 86 + FSL	27
115 mm	■	11 mm				■	■	■			5000	■	■		POG 10	13
115 mm	■	11 mm				■	■	■			5000				POG 86	17
405 mm			70 ... 340 mm	■	■			■	■		524 288				HDmag MHGP 400	18
150 mm			38 ... 65 mm	■				■			2500				ITD 70 A 4	27
80 mm			0.375 ... 1"	■				■	■		80 000			■	HS35	17, 23
58 mm	6,10 mm	8 ... 15 mm	8 ... 15 mm	■	□		□	■			5000				OptoPulse® EIL580	23, 28
58 mm	6,10 mm	8 ... 15 mm	8 ... 15 mm	■			□	■			65 536			■	OptoPulse® EIL580P	23, 28

□ Optional

Absolute encoders

Size (ø)	HeavyDuty	Solid Shaft (ø)	Hollow shaft (ø)	Through hollow shaft	Bearingless	EURO flange B10	Terminal box	Hybrid bearings	SSI	Profibus-DP / Profinet	Powerlink / DeviceNet	EtherCAT / CANopen	PoE / EtherNet/IP	Analog	TTL / HTL	Max. resolution singleturn	Max. resolution multiturn	Redundant sensing	Programmable	Product family	Page
105 mm	■		12 ... 20 mm	■		■	■	■	■	■				■	20 Bit	20 Bit	■			HMG 10	20
115 mm	■	11 mm				■	■	■	■	■				■	20 Bit	20 Bit	■			PMG 10	12, 14, 24
203 mm			50 ... 180 mm	■	■			■						■	17 Bit		■			HDmag MHAP 200	20
58 mm	6,10 mm	12 ... 14 mm	12 ... 14 mm	■				■	■	■	■				18 Bit	13 Bit		■		GBMMW / GBMMS	28
58 mm	6,10 mm	12 ... 14 mm	12 ... 14 mm	■				■	■	■	■				13 Bit	16 Bit		■		GXMMW / GXMMS	14
58 mm	6,10 mm	8 mm	8 mm	■				■	■	■	■				12 Bit	18 Bit		■		MAGRES BMMV 58	14, 25, 28

Products and applications

Steel making	Continuous casting		Main drives in rolling mills		Rolling mills and finishing lines		Overhead cranes		Product family	Page
	Electric arc furnace, blast furnace and converter	Ladle turret and cut to length	Auxiliary drives and roller table drives	Asynchronous main drives	Synchronous main drives	Auxiliary drives and roller beds	Coil boxes and loopers	Hoists		
■									POG 10	13
	■								GXMMW	14
	■						■		MAGRES BMMV 58	14, 25, 28
■	■						■		PMG 10	13, 14, 24
				■					HMG 10	20
				■					HDmag MHAP 200	20
			■				■		HOG 10	19, 24
			■						HOG 10 G	19
			■						HOG 165	19
			■						HDmag MHGP 400	18
		■							POG 86	17
		■				■	■		HOG 86	17, 23, 24
		■				■			HS35	17, 23
						■		■	OptoPulse® EIL580/EIL580P	23, 28
								■	GBMMS	28
								■	HOGS 100 S	27
								■	ITD 70 A 4	27
								■	HOG 10 + FSL/DSL	26
								■	HOG 86 + FSL	27

Pro+

CORPORATION



บริษัท โพรพลัส คอร์ปอเรชั่น จำกัด

22/354 หมู่ 4 ตำบลบึง อำเภอสรีราชา จังหวัดชลบุรี 20230

Mobile : 099-6103519 | 099-7358459

Tel : 033-130209

Email : Sales@propluscorp.co.th

Web : www.Propluscorp.co.th



@propluscorp

ยินดีให้คำปรึกษา หรือสอบถามสินค้าบริการได้ตลอดเวลา

 /propluscorp

 /abbjokabthailanddistributor

 /propluscorp

